



BEZNOSKA

We bring back joy to movement



Cerclage System

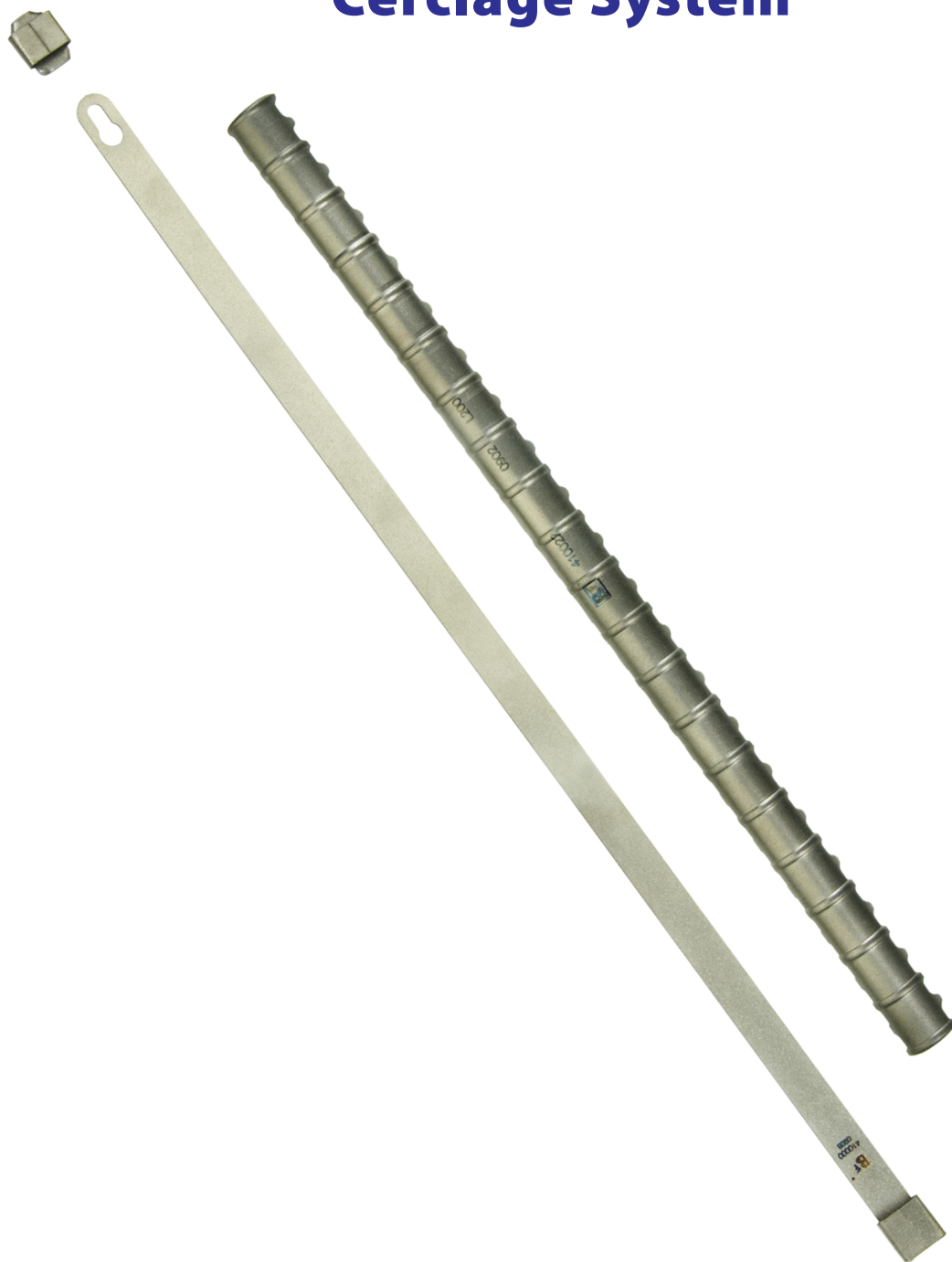

Cerclage System

REVISION SYSTEMS

Preface

The new cerclage system of BEZNOSKA Ltd. is a supplementary osteosynthetic method that was developed with the aim to solve successfully incidental situations and complications that may occur both during primary and revision surgeries of total joint replacements.

In the first scenario, there might appear fissures in the upper end of the femur when the femoral component is being inserted, either due to bone osteoporosis or poor matching between the implant and the prepared intramedullary canal. Also, the system might be a suitable solution in cases involving a fracture of the large trochanter.

In revision surgeries, the cerclage system is suitable for trap-door synthesis or trap-door osteotomy necessary for perfect removal of bone cement. The cerclage system is suited to fissures or fractures of long bones in exceptional cases only. The cerclage system consists of a compressive cerclage band, a rider with spikes, and groove-shaped plates with a limited contact facet. Compression of the band, in order to assure a higher osteosynthesis stability, is achieved by using a stretching device. For perfect fixation of the cerclage band on the uneven bone surface we use a rider with sharp spikes that are strung on the band. To increase the stabilizing effect of cerclage, we may add a pair of narrow plates being cross-positioned on the opposite side of the bone at an angle of 70 – 110 degrees.

The cerclage band and the rider with the spikes are made of pure titanium; the plates of titanium alloy. The surface of the implants is fine sand-blasted. The cerclage system is accompanied with a simple instrumentation set that allows its easy application.

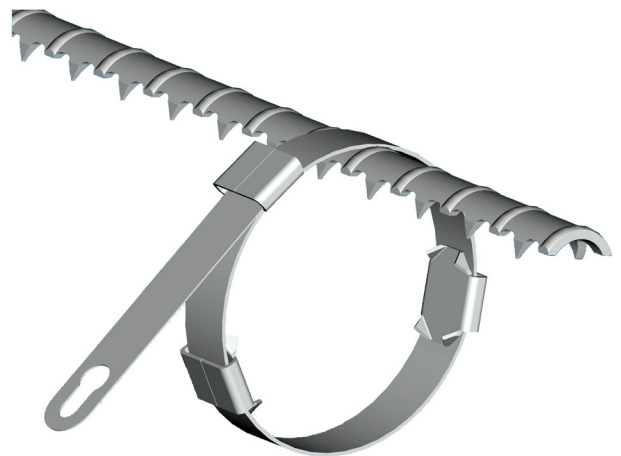



Cerclage Indication

a, primary total hip joint surgery

- fissures
- fractures of large trochanter
- osteoporosis

b, revision surgery

- trap-door synthesis or trap-door osteotomy
- higher implant stability if the bone is weak
- osteoporosis
- fracture prevention of inferior bone quality

c, fractures, fissures of long bones (exceptionally)

Mechanical test of the stability of the four-band cerclage set

The cerclage system durability test was performed at the station for testing of composite materials of AERO Vodochody Ltd. RVK 355 Prague-Letňany. The test sample was consisted of a four-band set of cerclage bands fastened onto an artificial bone (Fig.1).The bone was longitudinally cut. The compression load on the bone was exerted over the head of non-cemented stem (SF) that was pushed into the bone under increasing pressure. At a pressure of 3300 N (ISO 7206-4), the set of bands was still stable, without any sign of damage to the bands. At a pressure of 3860 N, the stem was driven 22 mm into the bone, the artificial bone cracked, and the eyelet of the upper cerclage band was partly stretched (Fig. 2, 3). The other bands remained unchanged.

The conclusion is that the cerclage system proved to have a high stability even under extremely high compression load simulated on a trial set (Fig. 1).



Fig. 1



Fig. 2



Fig. 3

■ Surgical Technique

1.

The mobile fastening part of the guiding device for coupling cerclage band must always be in front. To achieve this, keep turning the handle to the left (Fig. 1).

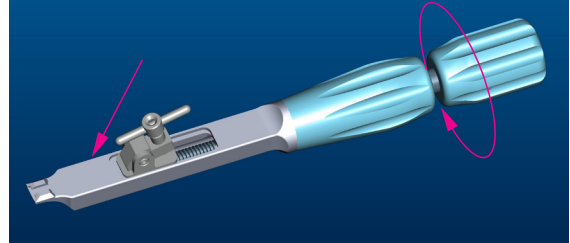

Fig. 1

2.

Push the guiding device under the bone from the medial side, so that the bent point of the guiding device protrudes laterally. Thread the end of the band into the eyelet of the guiding device and pull the band underneath the bone (Fig. 2, 3).

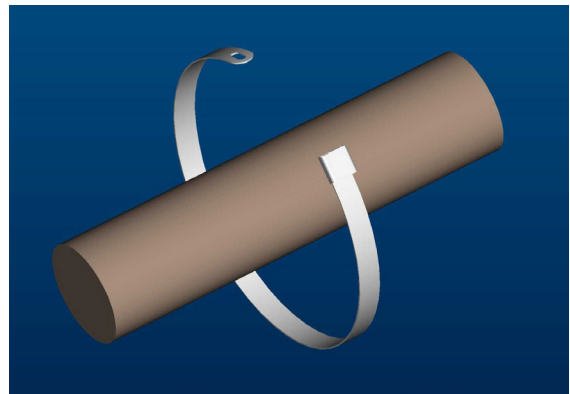

Fig. 3

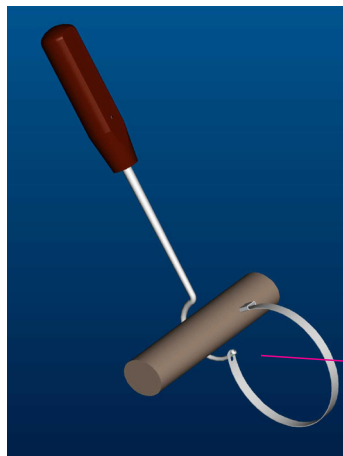
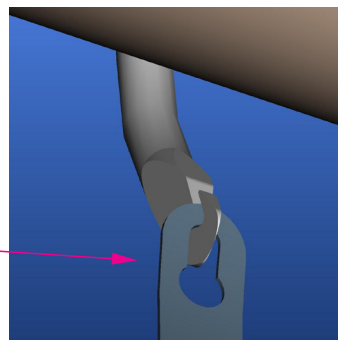

Fig. 2



3.

Using your hand, pull the end of the band through its eyelet and, manually or using a pair of nippers, pull the band tight around the bone (Fig. 4).

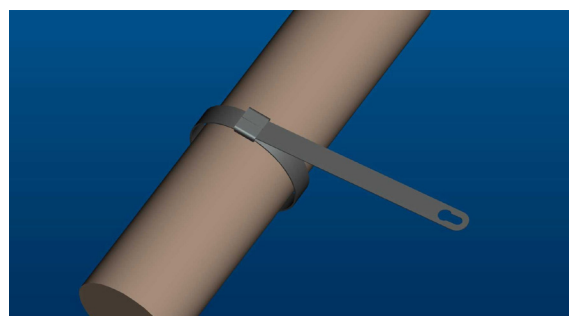

Fig. 4

4.

Take the loose end of the band and put it into the movable end of the stretcher. Fasten the band in the stretcher by turning the loop to the right. Keep turning to the right to tighten the band around the bone, until we find the tightness adequate (Fig. 5).

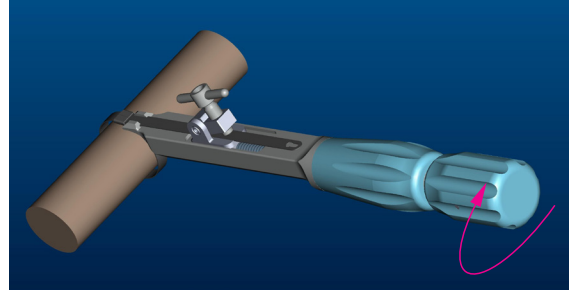

Fig. 5

5.

Now it is time to lift the stretcher up to draw it above the bone, thereby bending the band around the eyelet by more than 90° (Fig. 6). Next, loosen the loop and pull the stretcher out.

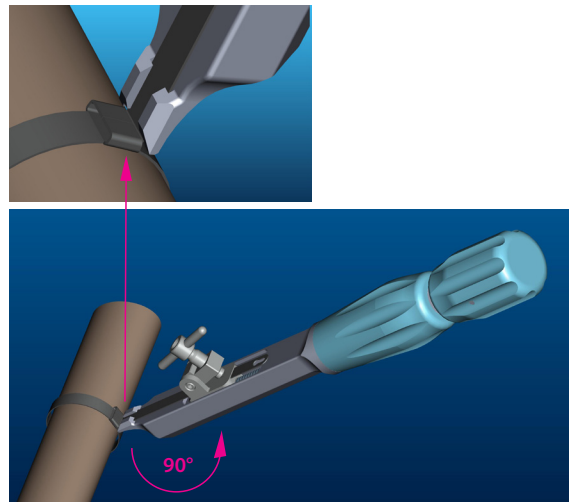

Fig. 6

6.

Apply the metal measuring tape and cut the band off with the nippers in the marked point (Fig. 7). Lay the nippers against the metal tape in the marked point.

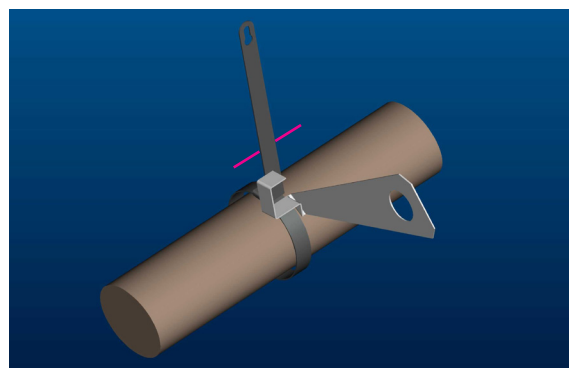

Fig. 7

7.

Put the bending device on the band in the place just cut, and bend the loose end of the band by about 90° (Fig. 8, 9, 10).

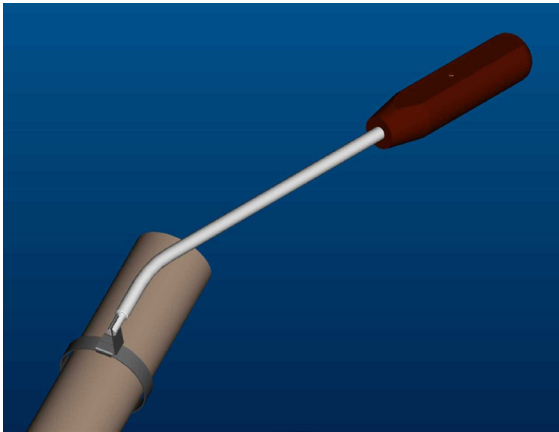

Fig. 8

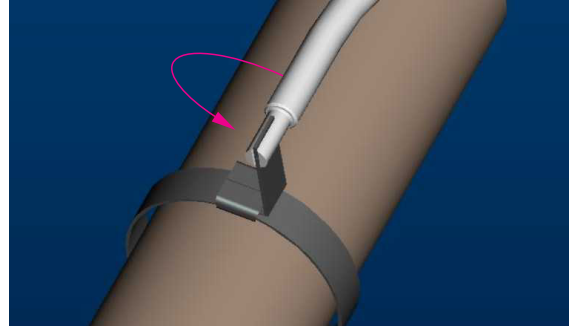

Fig. 9

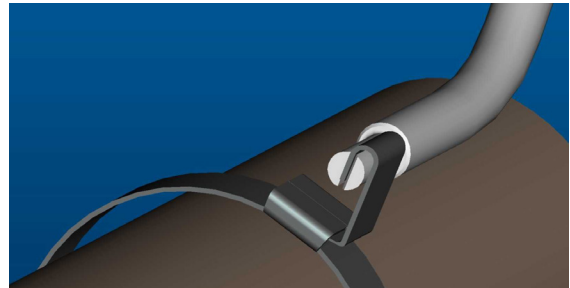

Fig. 10

8.

Pull out the bending device and, using the stamper, fold the bent part of the band onto the bone (Fig. 11,12,13,14).

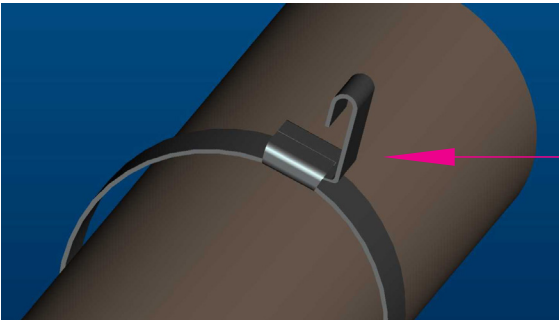

Fig. 11

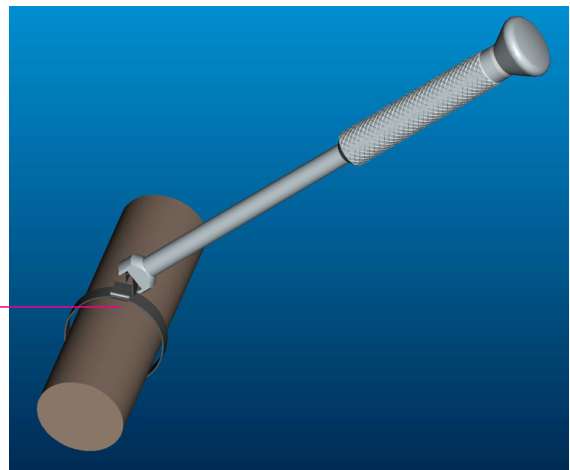

Fig. 12

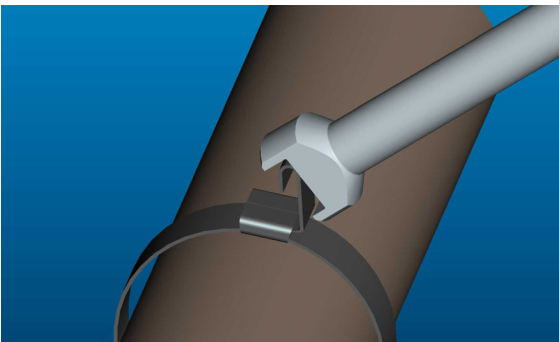

Fig. 13

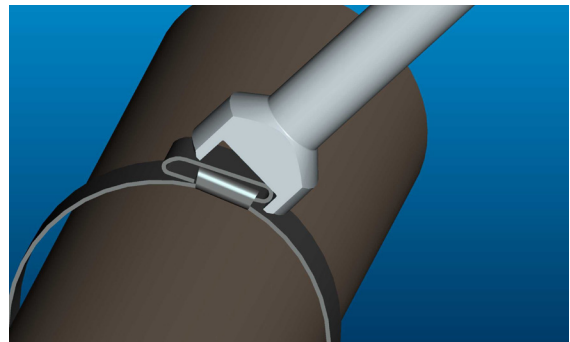

Fig. 14



■ Devices increasing the cerclage stability

If using the cerclage method on a very unevenly shaped bone (articulated), it helps to complement the band with at least one rider with sharp spikes (Fig. 15).

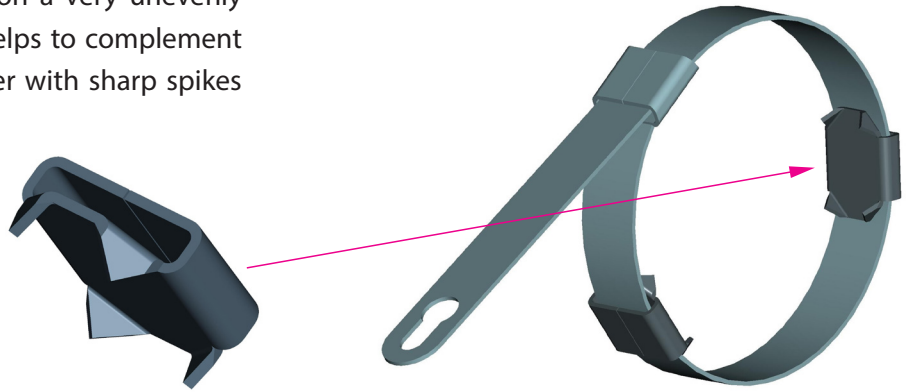

Fig. 15

For further improvement of stability, it is advised to apply a pair of plates with spikes that must be brought into a very close contact with the surface of the bone (Fig. 16,17).

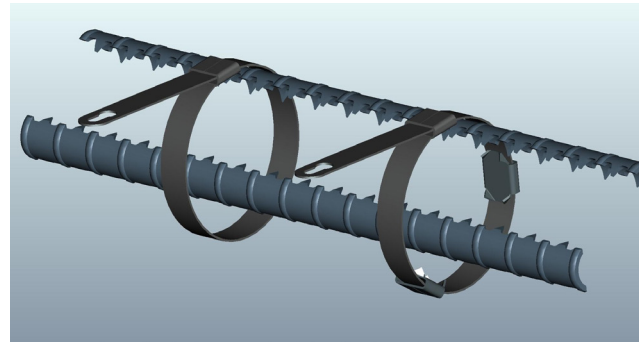

Fig. 16

From the anatomical and mechanical perspective, it is recommended to position the plates at an angle of 70° to 110° (Fig. 17).

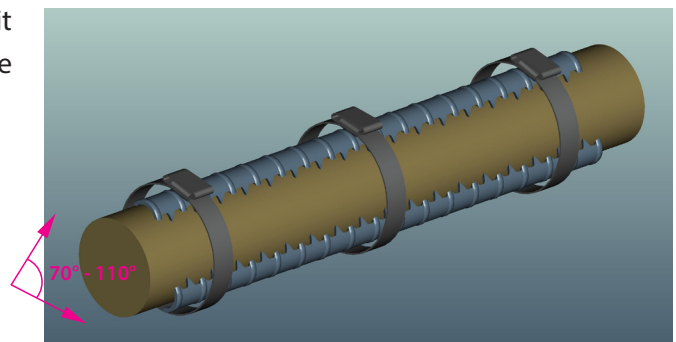

Fig. 17

■ Extraction of the cerclage band

1. Accessing the eyelet

PStraighten out the bent part of the band over the eyelet, using a flat tool – chisel or flat screwdriver, etc. (Fig. 1, 2).



Fig. 1



Fig. 2

2. Opening up the eyelet

Open up the eyelet using a flat tool and a pair of nippers (Fig. 3-6).



Fig. 3

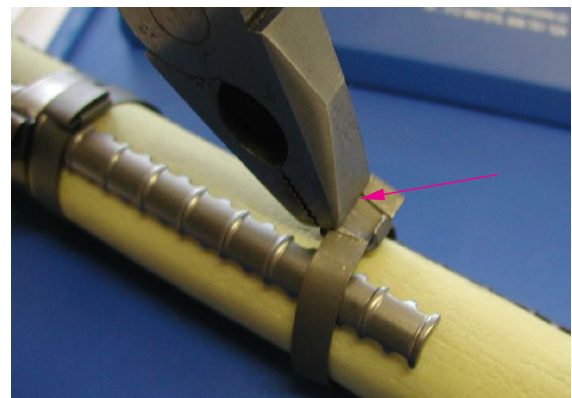

Fig. 4



Fig. 5

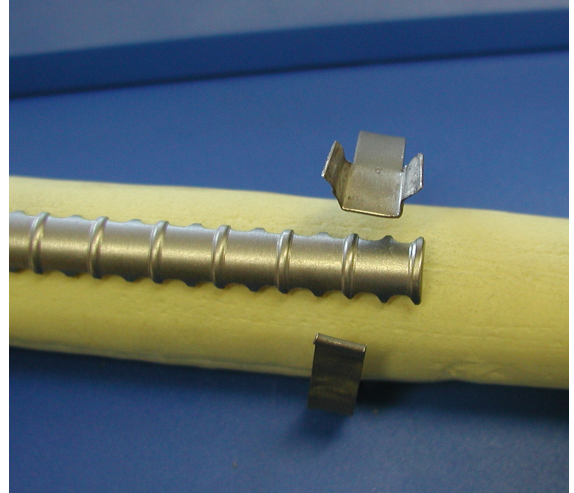

Fig. 6

3. Adjusting the locked end of the band

Squeeze the end of the band using a pair of nippers (Fig. 7) or remove it by clipping it off. This eliminates damaging soft tissue when pulling the band out.



Fig. 7



4. Removing the band

Grip the band eyelet with a pair of nippers and pull out it out.

■ Instrumentation Set

The set of instruments is laid out in a cassette, which facilitates easy orientation in the lay-out of the instruments, not only during transportation, storage, and preparation, but also during the surgery performance. While being transported, the cassette is placed in a container where it can be kept sterilized. The lay-out of the instruments is shown hereunder.



TOOLS FOR CERCLAGE SYSTEM APPLICATION NET LAY - OUT

	Denomination	Qty	Order number
1	Instrumentation set for cerclage		400000
2	Cerclage stretcher	1	401300
3	Guiding device, mid-right	1	401302
4	Guiding device, mid-left	1	401303
5	Guiding device, small right	1	401304
6	Guiding device, small left	1	401305
7	Measuring device	1	401306
8	Band bending device	1	401308
9	Stamper	1	401310
10	Nippers	1	506900

Note: The cassette lay-out is merely informative and may be changed as per future innovations.



■ Cerclage band

Material: Unalloyed titanium (ISO 5832-2)



Length [mm]	Width [mm]	Thickness [mm]	Order number
270	7,5	0,5	410000

■ Rider with spikes

Material: Unalloyed titanium (ISO 5832-2)



Length [mm]	Width [mm]	Height [mm]	Order number
12	9,5	4,5	410010

■ Cerclage plate

Material: Wrought titanium Ti6Al4V alloy (ISO 5832-3)



Length [mm]	Width [mm]	Thickness [mm]	Order number
170	10	2,5	410020
200			410022
230			410024



BEZNOSKA

We bring back joy to movement



■ Contact

Export:

tel.:  +420 312 811 221

 +420 312 811 225

export@beznoska.cz

CE 1014

BEZNOSKA, s.r.o.
Dělnická 2727, 272 01 Kladno, Czech Republic
www.beznoska.com, export@beznoska.cz

tel.: +420 312 660 670
GSM: +420 602 666 503
fax: +420 312 660 216
+420 312 662 464